

CLO507I-6DACTLWW

Acacia Evolution

Acacia E Wall hung basin WT

STYLE SEGMENT

- Modern

KEY SPECIFICATIONS

- Installation Type: Wall Hung
- Product Dimensions: 460 x 600 x 181
- Material: Vitreous China
- Color: White
- Overflow Hole: With
- Faucet Ledge: Yes
- Included Components: Overflow Ring, Wall Fixing Set for Lavatory, Installation Manual



SHIPPING WEIGHT

- Net Weight: 22.2
- Gross Weight: 24.74

KEY TECHNOLOGIES AND FEATURES

HYGIENE

- Proguard

COMFORT

- Complies with American Standard Quality Standards

CONVENIENCE

- Complies with American Standard Quality Standards

DURABILITY

- Complies with American Standard Quality Standards

SUSTAINABILITY

- Complies with American Standard Quality Standards

SAFETY

- Complies with American Standard Quality Standards

OTHERS

- NIL

STANDARDS AND CERTIFICATIONS

- TIS-792:2554(2011)

CLO507I-6DACTLWW

Acacia Evolution

Acacia E Wall hung basin WT

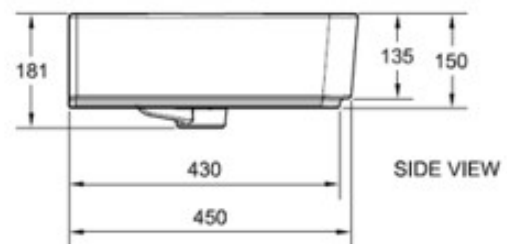
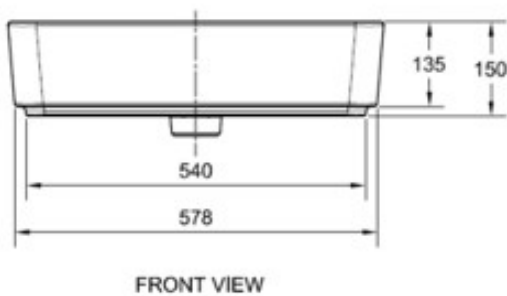
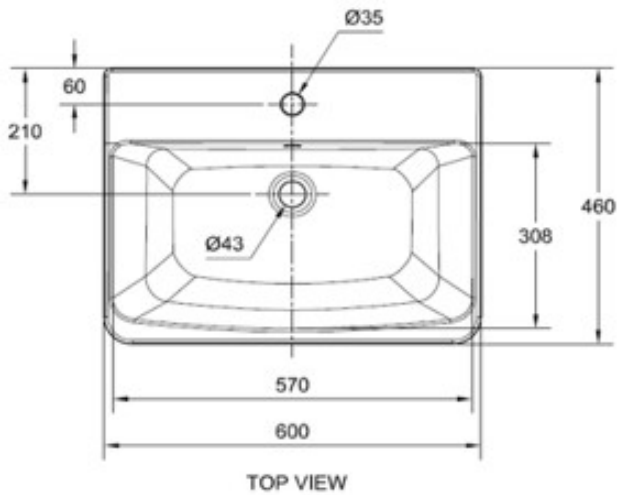

CL0507I-6DACTLWW

Acacia Evolution

Acacia E Wall hung basin WT

Item	Description	Acacia E WH Lavatory 600 mm_
Installations	Type	Wall Hung
Dimensions	Product (mm)	460 x 600 x 181
Material & Color	Material	Vitreous China
	Color	White
Features	Overflow Hole	With
	Faucet Ledge	Yes
Components	Included	Overflow Ring, Wall Fixing Set for Lavatory, Installation Manual
Shipping	Net Weight (kg)	22.2
	Gross Weight (kg)	24.74
	Product Weight (kg)	22.2
	Dimensions (mm)	504 x 614 x 215